

## SFP-MR27D-MMX-A

2GBASE, SFP, OC-48, SR, (SM)

1310 NM, 2 KM REACH, LC

## SFP-MR27D-MMX-A

2GBASE, SFP, OC-48, SR Transceiver

### Features

- Operating Data Rate up to 2.5Gbps
- 1310nm FP Laser Transmitter
- 2km with 9/125  $\mu$ m SMF
- Single 3.3V Power Supply
- Hot-Pluggable SFP Footprint Duplex LC Connector Interface
- Class 1 FDA and IEC60825-1 Laser Safety Compliant
- Operating Temperature: 0°C ~ +70°C
- Compliant with MSA SFP Specification
- Compliant with SFF-8472



### Applications

- Gigabit Ethernet Interface
- FC/2XFC Optical Interface
- STM1/STM4/STM6 Optical Interface
- Other Optical Links

### 1. Description

Approved Networks SFP-MR27D-MMX-A SFP SR Transceiver is a high performance, cost effective module which have a duplex LC optics interface. Standard AC coupled CML for high speed signal and LVTTTL control and monitor signals. The receiver section uses a PIN receiver and the transmitter uses a 1310 nm FP laser, up to 15dB link budge ensure this module 2GB Ethernet 2km application.

## 2. Absolute Maximum Ratings

Operation in excess of any absolute maximum ratings might cause permanent damage to this module.

Parameter	Symbol	Min	Typ	Max	Units
Storage Temperature	TS	-40		+85	°C
Power Supply Voltage	VCC	-0.5		4	V
Relative Humidity	RH	0		95	%

## 3. Recommended Operating Environment

Parameter	Symbol	Min	Typ	Max	Unit
Case operating Temperature (Commercial)	TC	0		70	°C
Supply Voltage	VCC	3.15	3.3	3.45	V
Supply Current	Icc			300	mA
Data Rate			2.488		Gbps

## 4. Electrical Characteristics

Parameter	Sym	Min.	Typ.	Max	Unit	Notes
<b>Transmitter</b>						
CML Inputs(Differential)	Vin	400		1600	mVpp	AC Coupled Inputs*(Note1)
Input Impedance (Differential)	Zin	85	100	115	ohms	Rin > 100 kohms@ DC
TX_Disable Assert Time	t_off			10	us	
TX_Dis	Disable		2		Vcc+0.3	
	Enable			0	0.8	
TX_FAULT	Fault		2		Vcc+0.3	V
	Normal		0		0.8	
<b>Receiver</b>						
CML Outputs (Differential)	Vout	400 8	00	1200	mVpp	AC Coupled Outputs*(Note1)
Output Impedance (Differential)	Zout	85	100	115	ohms	
RX_LOS	LOS		2		Vcc+0.3	V
	Normal		0		0.8	
MOD_DEF(0.2)	VoH	2.5			V	With Serial ID
	Vol	0		0.5		

**5. Optical and Electrical Characteristics**

Parameter	Symbol	Min	Typ	Max	Unit
9µm Core Diameter SMF	L		2		km
Data Rate			2.488		Gbps
Transmitter Section:					
Parameter	Symbol	Min	Typ	Max	Unit
Center Wavelength	$\lambda_c$	1260	1310	1360	nm
Spectral Width	$\sigma$			3	nm
Optical Output Power	Pout	-10		-3	dBm
Extinction Ratio	ER	8.2			dB
TX_Disable ASSERT	tr/tf			150	ps
Total Jitter <sup>(Note3)</sup>	TJ			0.07	UI
Pout @ TX Disable Asserted	Pout			-45	dBm
Output Optical Eye	ITU-T G.957 Compliant				
Receiver Section:					
Parameter	Symbol	Min	Typ	Max	Unit
Optical Input Wavelength	$\lambda_c$	1260		1600	nm
Receiver Overload	Pol	-3			dBm
RX Sensitivity	Sen			-24	dBm
RX_LOS Assert	LOS A	-35			dBm
RX_LOS De-assert	LOS D			-19	dBm
RX_LOS Hysteresis	LOS H	0.5			dB

**Notes:**

1. LVPECL logic, internally AC coupled
2. Output power is measured by coupling into a 9/125 mm multi-mode fiber.
3. Filtered, measured with a PRBS 223-1 test pattern @2500Mbps.
4. Minimum average optical power is measured at BER less than 1E-12, with 2<sup>23</sup>-1 PRBS and ER=9 dB

**6. Regulatory Compliance**

Feature	Standard	Performance
Electrostatic Discharge (ESD) to the Electrical Pins	MIL-STD-883G Method 3015.7	Class 1C (>1000V)
Electrostatic Discharge to the enclosure	EN 55024:1998+A1+A2 IEC-61000-4-2 GR-1089-CORE	Compliant with standards
Electromagnetic Interference (EMI)	FCC Part 15 Class B EN55032:2012 CISPR 22B :2006 VCCI Class B	Compliant with standards Noise frequency range: 0.15MHz to 6GHz. Good system EMI design practice required to achieve Class B margins. System margins are dependent on customer host board and chassis design.
Immunity	EN 55024:1998+A1+A2 IEC 61000-4-3	Compliant with standards. 1KHz sine-wave, 80% AM, from 80MHz to 1GHz. No effect on transmitter/receiver performance is detectable between these limits.
Component Recognition	UL and CUL EN60950-1:2006	UL file E317337 TÜV Certificate No. 50135086(CB scheme )
RoHS6	2002/95/EC 4.1&4.2 2005/747/EC 5&7&13	Compliant with standards

**7. Pin Assignment and Description**

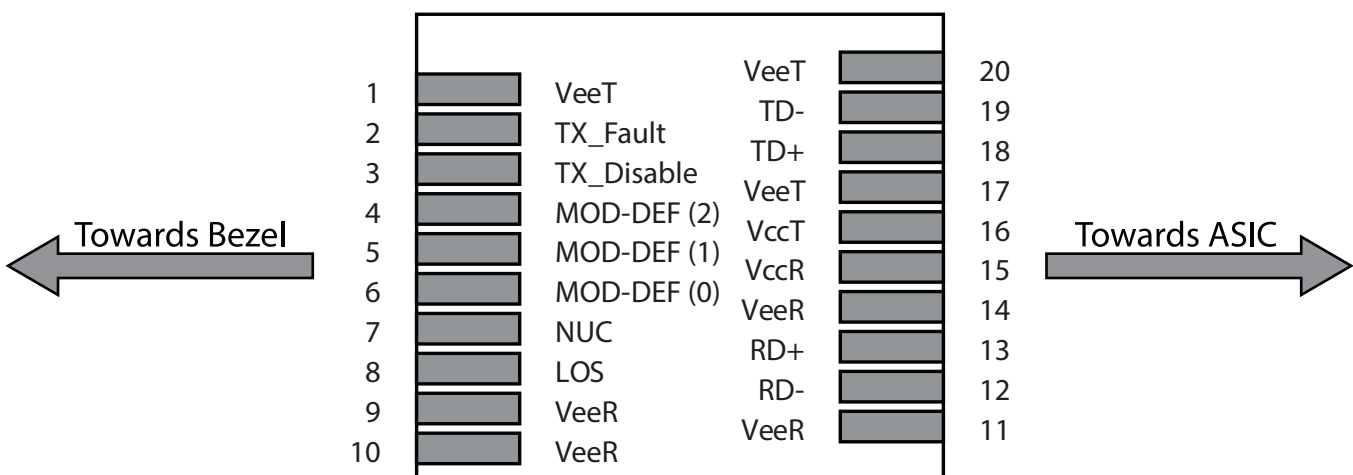

## 8. Pin Function Definitions

Pin No	Name	Function	Plug Seq	Notes
1	VeeT	Transmitter Ground	1	5
2	TX Fault	Transmitter Fault Indication	3	1
3	TX Disable	Transmitter Disable	3	2
4	MOD-DEF2	Module Definition	2	3
5	MOD-DEF1	Module Definition 1	3	3
6	MOD-DEF0	Module Definition 0	3	3
7	Rate Select	Not Connected	3	N/A
8	LOS	Loss of Signal	3	4
9	VeeR	Receiver Ground	1	5
10	VeeR	Receiver Ground	1	5
11	VeeR	Receiver Ground	1	5
12	RD-	Inv. Received Data Out	3	6
13	RD+	Received Data Out	3	7
14	VeeR	Receiver Ground	3	5
15	VccR	Receiver Power	2	7
16	VccT	Transmitter Power	2	7
17	VeeT	Transmitter Ground	1	5
18	TD+	Transmit Data In	3	8
19	TD-	Inv. Transmit In	3	8
20	VeeT	Transmitter Ground	1	5

### Notes:

1. TX Fault is an open collector/drain output, which should be pulled up with a 4.7K–10K resistor on the host board. Pull up voltage between 2.0V and  $V_{ccT}/R+0.3V$ . When high, output indicates a laser fault of some kind. Low indicates normal operation. In the low state, the output will be pulled to  $< 0.8V$ .
2. TX disable is an input that is used to shut down the transmitter optical output. It is pulled up within the module with a 4.7 – 10 K resistor. Its states are: Low (0 – 0.8V): Transmitter on.( $>0.8, < 2.0V$ ): Undefined; High (2.0 – 3.465V): Transmitter Disabled Open: Transmitter Disabled;
3. Mod-Def 0,1,2.These are the module definition pins. They should be pulled up with a 4.7K -10k resistor on the host board. The pull-up voltage shall be  $V_{ccT}$  or  $V_{ccR}$ . Mod-Def 0 is grounded by the module to indicate that the module is present; Mod-Def 1 is the clock line of two wire serial interface for serial ID; Mod-Def 2 is the data line of two wire serial interface for serial ID.
4. LOS (Loss of Signal) is an open collector/drain output, which should be pulled up with a 4.7K –10K resistor. Pull up voltage between 2.0V and  $V_{ccT}/R+0.3V$ . When high, this output indicates the received optical power is below the worst-case receiver Sensitivity (as defined by the standard in use). Low indicates normal operation. In the low state, the output will be pulled to  $<0.8V$ .

5. VeeR and VeeT may be internally connected within the SFP module.
6. RD-/+: These are the differential receiver outputs. They are AC coupled 100 differential Lines which should be terminated with 100 (differential) at the user SERDES. The AC coupling is done inside the module and is thus not required on the host board. The voltage swing on these lines will be between 400 and 2000 mV differential (200 –1000 mV single ended) when properly terminated.
7. VccR and VccT are the receiver and transmitter power supplies. They are defined as  $3.3V \pm 5\%$  at the SFP connector pin. Maximum supply current is 300mA. Recommended host board power supply filtering is shown below. Inductors with DC resistance of less than 1 ohm should be used in order to maintain the required voltage at the SFP input pin with 3.3V supply voltage When the recommended supply-filtering network is used, hot plugging of the SFP transceiver module will result in an inrush current of no more than 30mA greater than the steady state value. VccR and VccT may be internally connected within the SFP transceiver module.
8. TD-/+: These are the differential transmitter inputs. They are AC-coupled, differential lines with 100 differential terminations inside the module. The AC coupling is done inside the module and is thus not required on the host board. The inputs will accept differential swings of 400 – 2000mV (200 – 1000mV single-ended)

## 9. SFP Module EEPROM Information and Management

The serial interface uses the 2-wire serial CMOS EEPROM protocol defined for the ATMEL. AT24C02/04 family of component. When the serial protocol is activated, the host generates the serial clock signal (SCL). The positive edge clocks data into those segments of the EEPROM that are not write protected within the SFP transceiver. The negative edge clocks data from the SFP transceiver. The serial data signal (SDA) is bi-directional for serial data transfer. The host uses SDA in conjunction with SCL to mark the start and end of serial protocol activation. The memories are organized as a series of 8-bit data words that can be addressed individually or sequentially .The Module provides diagnostic information about the present operating conditions. The transceiver generates this diagnostic data by digitization of internal analog signals. Calibration and alarm/warning threshold data is written during device manufacture. Received Power monitoring, transmitted power monitoring, bias current monitoring, supply voltage monitoring and temperature monitoring all are implemented. If the module is defined as external calibrated, the diagnostic data are raw A/D values and must be converted to real world units using calibration constants stored in EEPROM locations 56 – 95 at wire serial bus address A2h.The digital diagnostic memory map specific data field defines as following .For detail EEPROM information please refer to the related document of SFF 8472 Rev 9.3. EEPROM Serial

# SFP-MR27D-MMX-A

2GBASE, SFP, OC-48, SR, (SM)

1310 NM, 2 KM REACH, LC

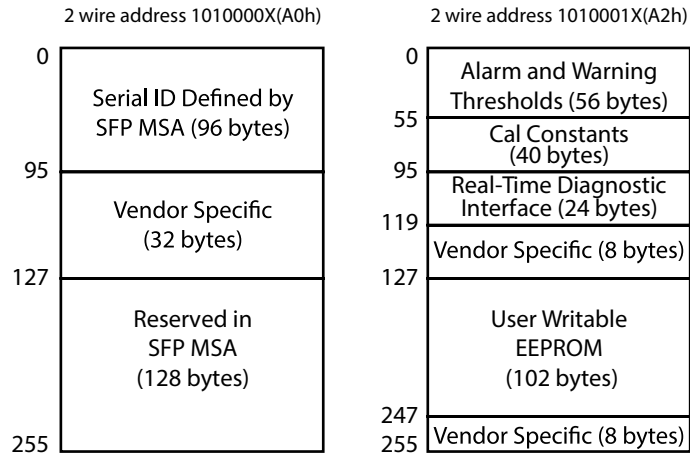

Addr.	Size(Bytes)	Name of Field	Hex	Description
<b>BASE ID FIELDS</b>				
0	1	Identifier	03	SFP
1	1	Ext. Identifier	04	SFP function is defined by serial ID only
2	1	Connector	07	LC Connector
3-10	8	Transceiver	XX	Transmitter Code
11	1	Encoding	03	NRZ
12	1	BR, Nominal	19	2.488Gbps
13	1	Reserved	00	
14	1	Length (9µm) km	02	Transceiver Transmit Distance
15	1	Length(9µm) 100m	14	
16	1	Length (50µm) 10m	00	
17	1	Length(62.5µm) 10m	00	
18	1	Length (Copper)	00	Not Compliant
19	1	Reserved	00	
20-35	16	Vendor name	XX	(ASCII)
36	1	Reserved	00	
37-39	3	Vendor OUI	XX	
40-55	16	Vendor PN	XX	Transceiver part number
56-59	4V	endor rev	XX	ASCII
60-61	2	Wavelength	05 1E	1310nm
62	1	Reserved	00	
63	1	CC_BASE	Check Sum (Variable)	Check Code for Base ID Fields

Addr.	Size(Bytes)	Name of Field	Hex	Description
<b>EXTENDED ID FIELDS</b>				
64-65	2	Options	00 1A	TX_DISABLE, TX_FAULT and Loss of Signal implemented.
66	1	BR,max	00	
67	1	BR,min	00	
68-83	16	Vendor SN	XX	Serial Number of transceiver (ASCII)
84-91	8	Date code	XX	Manufactory date code.
92	1	Diagnostic Monitoring Type	XX	Digital Diagnostic Monitoring Implemented
93	1	Enhanced Options	XX	Optional Flags
94	1	SFF_8472 Compliance	XX	01 for Diagnostics (Rev9.3SFF-8472).
95	1	CC_EXT Checksum	XX	Checksum for extended ID Field.
<b>VENDOR SPECIFIC ID FIELDS</b>				
96-127	32	Vendor Specific	Read only	Depends on customer information
128-255	128	Reserved	Read only	

**Note:**

The “xx” byte should be filled in according to practical case .For more information. please refer to the related document of SFP Multi-Source Agreement (MSA).

**10. Recommended Circuit**

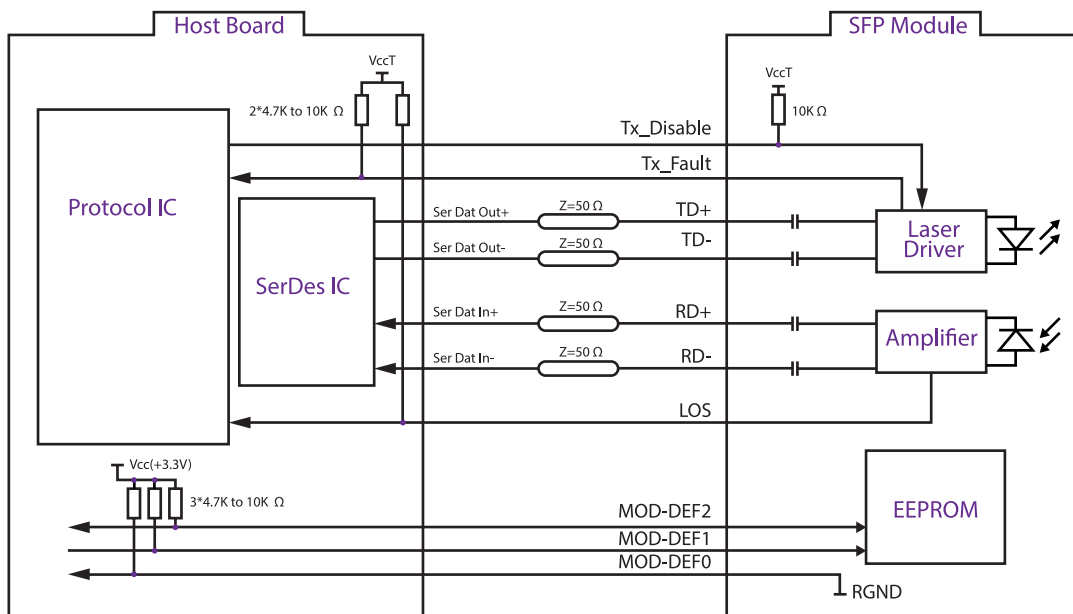



# SFP-MR27D-MMX-A

2GBASE, SFP, OC-48, SR, (SM)

1310 NM, 2 KM REACH, LC

## 11. Mechanical Dimensions

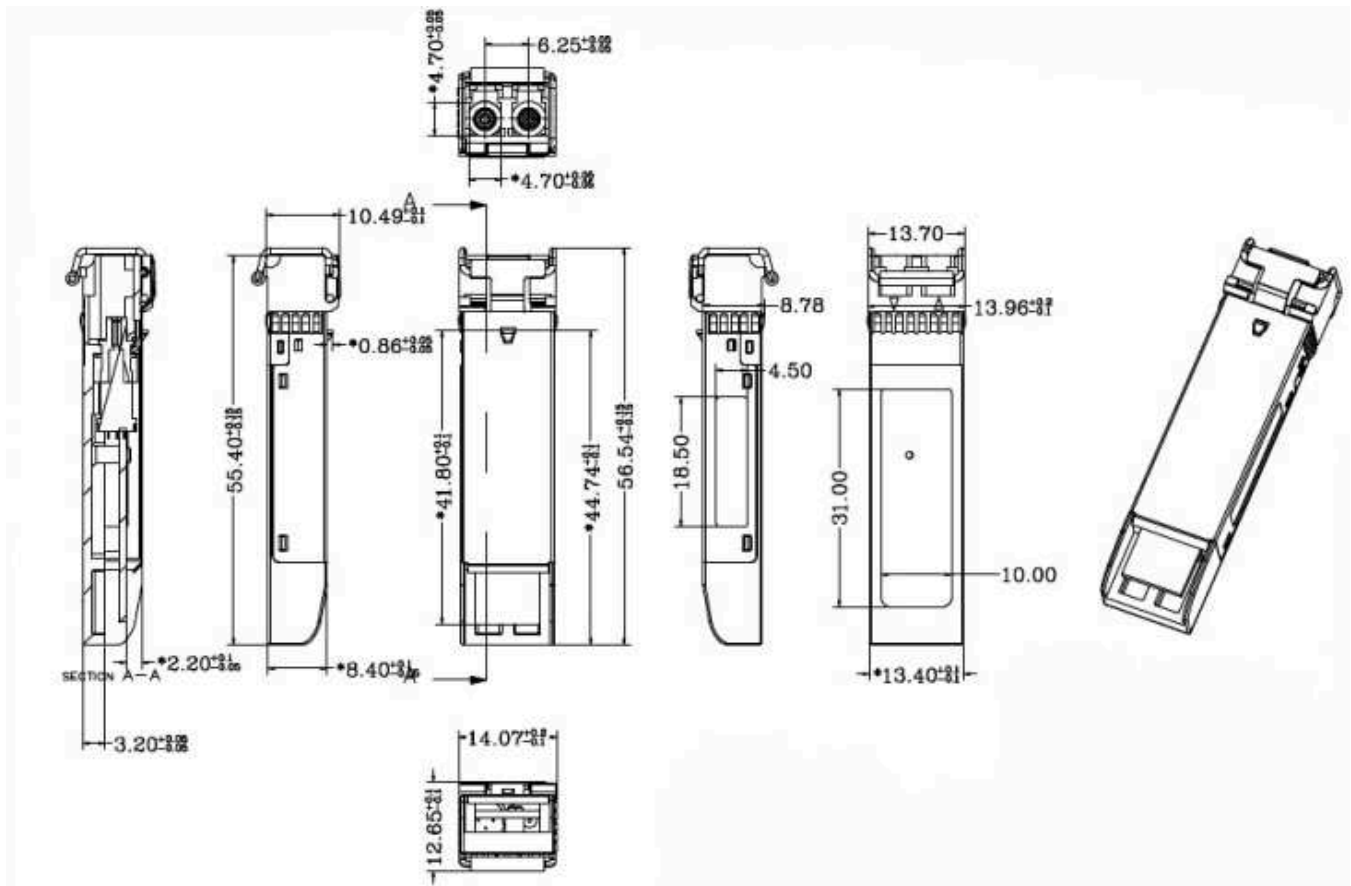

## 12. Contact Information

Approved Networks is a leading supplier of Network Transceivers and Connectivity products to Channel Partners, Resellers, and OEMs. With more than 9 years of direct industry experience, our products are resident in the most demanding and mission critical functional networks Worldwide. We serve as a Master Distributor to the largest CMs in the world and deploy the most rigorous testing and firmware management programs to bring the highest level of functional product to the market at a cost that makes sense.

Corporate Offices: **Approved Networks, Inc.**

Tel: 800.590.9535

Web: <http://www.approvednetworks.com>