

**DWDM-X2-31.90-A**  
10GBASE, DWDM, X2, ZR Transceiver

## Features

- Wavelength selectable to C-band ITU-T grid wavelengths
- Suitable for use in 100GHz channel spacing DWDM systems
- Compatible with X2 MSA Rev2.0b
- Support of IEEE 802.3ae 10GBASE-ER at 10.3125Gbps
- Transmission Distance up to 80Km(SMF)
- SC Receptacle DWDM Cooled EA Laser and APD photodiode
- SC Duplex Optical Connector
- Hot Pluggable 70-PIN Connector with XAUI Electrical Interface
- Management and control via MDIO 2-wire interface
- Power Supply : +5V, +3.3V, APS(+1.2V)
- Diagnostic Optics Monitoring
- Temperature Range: 0-5~ 70 °C
- ROHS Compatible



## Applications

- 10GE Ethernet switches and routers
- 10GE Core-routers
- 10GE Storage
- DWDM Systems

## 1. Product Description

The DWDM-X2-31.90-A is a highly integrated Serial optical transponder module for high-speed, 10Gbit/s data transmission applications. 4x3.125Gbps Ethernet Signal Input by XAUI Interface. An integrated Coder / Decoder and multiplexer / demultiplexer (SERDES: Serializer / Deserializer). Designing for 10km Transmission with an uncooled directly modulated 1310nm DFB Laser. Digital diagnostics functions are available via a 2-wire serial interface, as specified in the XENPAK MSA 3.0.

## 2. Absolute Maximum Ratings

Any stress beyond the maximum ratings can result in permanent damage. The device specifications are guaranteed only under the recommended operating conditions.

| Parameter                         | Symbol   | Min  | Max | Unit | Notes                   |
|-----------------------------------|----------|------|-----|------|-------------------------|
| Storage Ambient Temperature Range |          | -40  | +85 | °C   | non condensing          |
| Powered Case Temperature Range    |          | 0    | +70 | °C   | non condensing          |
| Adaptable Power Supply (APS)      | Vapsense | 0    | 1.5 | V    | Voltage @ Pin APS Sense |
| Supply Voltage Range @ 3.3V       | Vcc3     | -0.5 | 4.0 | V    |                         |

## 2. Recommended Operating Conditions

| Parameter                  | Symbol | Min   | Typical | Max   | Unit |
|----------------------------|--------|-------|---------|-------|------|
| Operating Case Temperature | Tc     | 0     |         | +70   | °C   |
| Power Supply Voltage       | VCC5   | 4.75  | 5.0     | 5.25  | V    |
|                            | VCC3   | 3.14  | 3.3     | 3.47  |      |
|                            | VAPS   | 1.152 | 1.2     | 1.248 |      |
| Power Dissipation          | PD     |       |         | 4     | W    |

## 3. XAUI I/O Characteristics

| Parameter                         | Symbol | Min  | Typ.  | Max  | Unit  | Note                      |
|-----------------------------------|--------|------|-------|------|-------|---------------------------|
| XAUI Data Rate                    | DR     |      | 3.125 |      | Gb/s  |                           |
| XAUI Baud Rate Tolerance          |        | -100 |       | +100 | ppm   | Relative Tolerance        |
| Differential Input Voltage Swing  |        | 220  |       | 1600 | mv    | 8B/10B Coded Input Signal |
| Differential Output Voltage Swing |        | 800  |       | 1600 | mVp-p | RLOAD = 100Ω ± 5%         |
| Differential Input Impedance      |        | 80   | 100   | 120  | Ω     |                           |
| Total Output Jitter               | TJXAUI |      |       | 0.35 | UI    | no pre-equalization       |
| Total Deterministic Output Jitter | DJXAUI |      |       | 0.17 | UI    | no pre-equalization       |

#### 4. Optical Interface

| Transmitter                         |           |                   |             |                   |         |       |
|-------------------------------------|-----------|-------------------|-------------|-------------------|---------|-------|
| Parameter                           | Symbol    | Min               | Typ         | Max               | Unit    | Notes |
| Operating Range                     |           |                   |             | 80                | Km      |       |
| Operating Data Rate                 |           |                   | 10.3125     |                   | Gb/s    |       |
| Optical Transmit Power              | Po        | -1.0              |             | +2.0              | dBm     |       |
| Center Wavelength-Start of Life [1] | $\lambda$ | $\lambda_c - 25$  | $\lambda_c$ | $\lambda_c + 25$  | pm      |       |
| Center Wavelength-End of life [1]   | $\lambda$ | $\lambda_c - 100$ | $\lambda_c$ | $\lambda_c + 100$ | pm      |       |
| SMSR                                | SWSR      | 30                |             |                   | dB      |       |
| Extinction Ratio                    | ER        | 9.0               |             |                   |         |       |
| Optical Modulation Amplitude        | OMA       | 500               |             |                   | $\mu$ W |       |
| Transmitter and Dispersion Penalty  | TDP       |                   |             | 3.2               | dB      |       |
| Receiver                            |           |                   |             |                   |         |       |
| Parameter                           | Symbol    | Min               | Typ         | Max               | Unit    | Notes |
| Operating Data Rate                 |           |                   | 10.3125     |                   | Gb/s    |       |
| Overload                            | Po        | 0.5               |             |                   | dBm     |       |
| Sensitivity in 10.3G(OMA)           | OMA0      |                   |             | -23.5             | dBm     | 1     |
| Stressed Sensitivity in 10.3G(OMA)  | OMAst     |                   |             | -22.0             | dBm     | 1     |

**Notes:**

1. Measured at 10.3125Gb/s, Non-framed PRBS2<sup>31</sup>-1, NRZ

5. Electrical PAD Layout

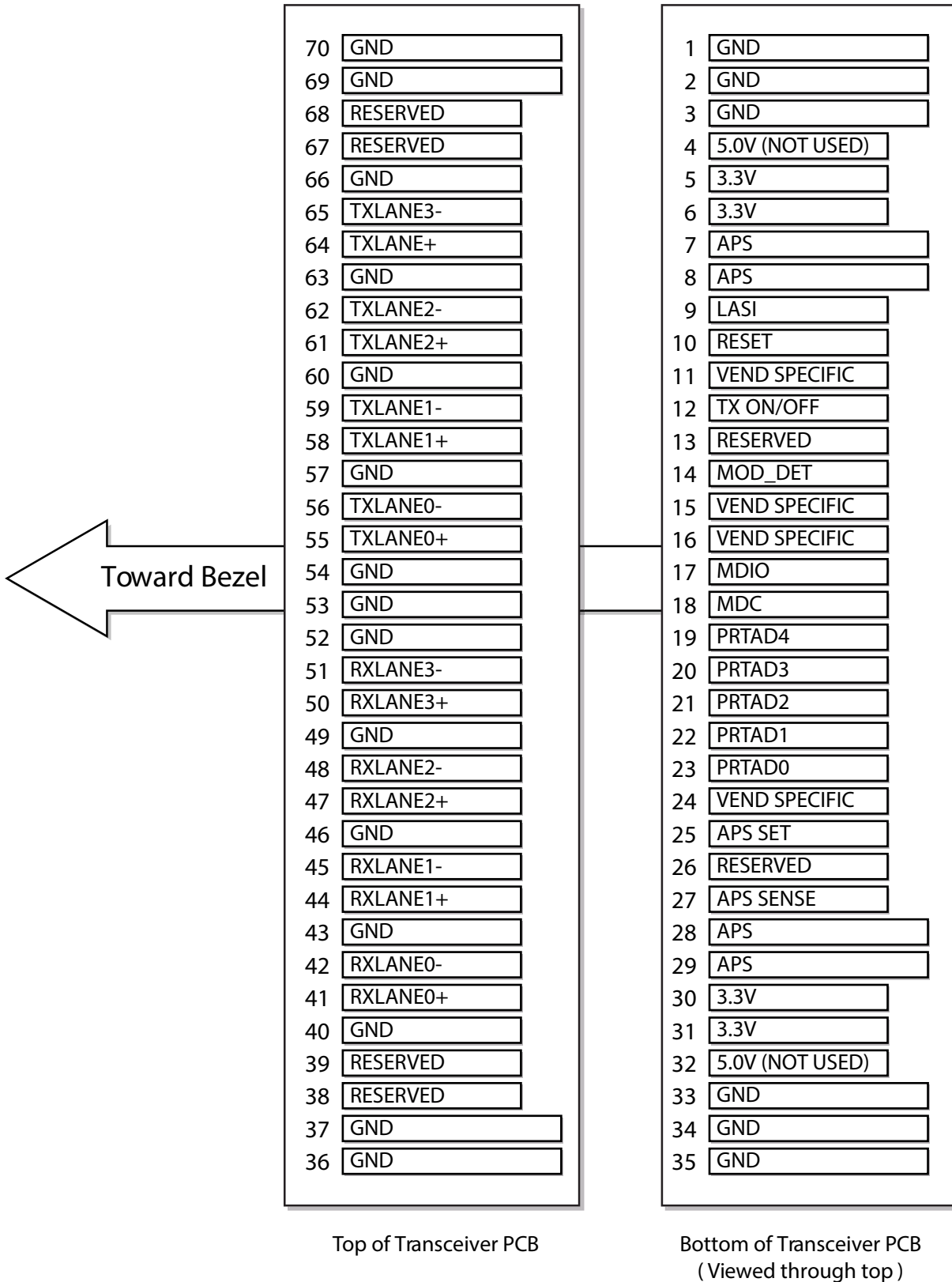

6. Host PCB X2 PINOUT

|    |                          |                 |          |                          |    |
|----|--------------------------|-----------------|----------|--------------------------|----|
| 1  | <input type="checkbox"/> | GND             | GND      | <input type="checkbox"/> | 70 |
| 2  | <input type="checkbox"/> | GND             | GND      | <input type="checkbox"/> | 69 |
| 3  | <input type="checkbox"/> | GND             | RESERVED | <input type="checkbox"/> | 68 |
| 4  | <input type="checkbox"/> | 5.0V (NOT USED) | RESERVED | <input type="checkbox"/> | 67 |
| 5  | <input type="checkbox"/> | 3.3V            | GND      | <input type="checkbox"/> | 66 |
| 6  | <input type="checkbox"/> | 3.3V            | TXLANE3- | <input type="checkbox"/> | 65 |
| 7  | <input type="checkbox"/> | APS             | TXLANE+  | <input type="checkbox"/> | 64 |
| 8  | <input type="checkbox"/> | APS             | GND      | <input type="checkbox"/> | 63 |
| 9  | <input type="checkbox"/> | LASI            | TXLANE2- | <input type="checkbox"/> | 62 |
| 10 | <input type="checkbox"/> | RESET           | TXLANE2+ | <input type="checkbox"/> | 61 |
| 11 | <input type="checkbox"/> | VEND SPECIFIC   | GND      | <input type="checkbox"/> | 60 |
| 12 | <input type="checkbox"/> | TX ON/OFF       | TXLANE1- | <input type="checkbox"/> | 59 |
| 13 | <input type="checkbox"/> | RESERVED        | TXLANE1+ | <input type="checkbox"/> | 58 |
| 14 | <input type="checkbox"/> | MOD_DET         | GND      | <input type="checkbox"/> | 57 |
| 15 | <input type="checkbox"/> | VEND SPECIFIC   | TXLANE0- | <input type="checkbox"/> | 56 |
| 16 | <input type="checkbox"/> | VEND SPECIFIC   | TXLANE0+ | <input type="checkbox"/> | 55 |
| 17 | <input type="checkbox"/> | MDIO            | GND      | <input type="checkbox"/> | 54 |
| 18 | <input type="checkbox"/> | MDC             | GND      | <input type="checkbox"/> | 53 |
| 19 | <input type="checkbox"/> | PRTAD4          | GND      | <input type="checkbox"/> | 52 |
| 20 | <input type="checkbox"/> | PRTAD3          | RXLANE3- | <input type="checkbox"/> | 51 |
| 21 | <input type="checkbox"/> | PRTAD2          | RXLANE3+ | <input type="checkbox"/> | 50 |
| 22 | <input type="checkbox"/> | PRTAD1          | GND      | <input type="checkbox"/> | 49 |
| 23 | <input type="checkbox"/> | PRTAD0          | RXLANE2- | <input type="checkbox"/> | 48 |
| 24 | <input type="checkbox"/> | VEND SPECIFIC   | RXLANE2+ | <input type="checkbox"/> | 47 |
| 25 | <input type="checkbox"/> | APS SET         | GND      | <input type="checkbox"/> | 46 |
| 26 | <input type="checkbox"/> | RESERVED        | RXLANE1- | <input type="checkbox"/> | 45 |
| 27 | <input type="checkbox"/> | APS SENSE       | RXLANE1+ | <input type="checkbox"/> | 44 |
| 28 | <input type="checkbox"/> | APS             | GND      | <input type="checkbox"/> | 43 |
| 29 | <input type="checkbox"/> | APS             | RXLANE0- | <input type="checkbox"/> | 42 |
| 30 | <input type="checkbox"/> | 3.3V            | RXLANE0+ | <input type="checkbox"/> | 41 |
| 31 | <input type="checkbox"/> | 3.3V            | GND      | <input type="checkbox"/> | 40 |
| 32 | <input type="checkbox"/> | 5.0V (NOT USED) | RESERVED | <input type="checkbox"/> | 39 |
| 33 | <input type="checkbox"/> | GND             | RESERVED | <input type="checkbox"/> | 38 |
| 34 | <input type="checkbox"/> | GND             | GND      | <input type="checkbox"/> | 37 |
| 35 | <input type="checkbox"/> | GND             | GND      | <input type="checkbox"/> | 36 |

## 7. Pin Descriptions

| Pin | Name          | Dir | Logic                | Function   |
|-----|---------------|-----|----------------------|--|
| 1   | GND           |     |                      | Electrical Ground  |
| 2   | GND           |     |                      | Electrical Ground  |
| 3   | GND           |     |                      | Electrical Ground  |
| 4   | 5.0V          |     |                      | Power  |
| 5   | 3.3V          |     |                      | Power  |
| 6   | 3.3V          |     |                      | Power  |
| 7   | APS           |     |                      | Adaptive Power Supply  |
| 8   | APS           |     |                      | Adaptive Power Supply  |
| 9   | LASI          | O   | 1.2V CMOS Open Drain | Link Alarm Status Interrupt, low active, Open Drain Output A pull-up resistor with 10-22KΩ to 1,2V is expected.<br>Logic High: Normal Operation<br>Logic Low: Link Alarm is indicated                    |
| 10  | Reset         | I   | 1.2V CMOS Open Drain | Low active Reset Input 10KΩ pull-up on Transceiver<br>Logic high = Normal Operation<br>Logic Low = Reset asserted  |
| 11  | VEND SPECIFIC |     |                      | Vendor Specific Pin, leave unconnected   |
| 12  | TX ON/OFF     | I   | 1.2V CMOS Open Drain | High active Transmitter Enable Input 10KΩ pull-up on Transceiver<br>Logic high = Transmitter active (normal operation) And Register Bit 1.9.0 set to low as well<br>Logic Low = shut down of Transmitter |
| 13  | RESERVED      |     |                      | RESERVED   |
| 14  | MOD DETECT    | O   |                      | 1kΩ to Ground On Transceiver   |
| 15  | VEND SPECIFIC |     |                      | Vendor Specific Pin, leave unconnected   |
| 16  | VEND SPECIFIC |     |                      | Vendor Specific Pin, leave unconnected   |
| 17  | MDIO          | I/O | 1.2V CMOS            | Management Data I/O. Requires external 10-22 kΩ pullup to 1.2 V on host.   |
| 18  | MDC           | I   | 1.2V CMOS            | Management Clock Input   |
| 19  | PRTAD4        | I   |                      | Port Address Bit 4(LOW=0)  |
| 20  | PRTAD3        | I   |                      | Port Address Bit 3(LOW=0)  |
| 21  | PRTAD2        | I   |                      | Port Address Bit 2(LOW=0)  |
| 22  | PRTAD1        | I   |                      | Port Address Bit 1(LOW=0)  |
| 23  | PRTAD0        | I   |                      | Port Address Bit 0(LOW=0)  |
| 24  | VEND SPECIFIC |     |                      | Vendor Specific Pin,. leave unconnected  |
| 25  | APS SET       | I   |                      | Feedback Input for APS, Input of APS Setting Resistor  |

| Pin | Name       | Dir | Logic | Function                                 |
|-----|------------|-----|-------|--|
| 26  | RESERVED   |     |       | RESERVED                                 |
| 27  | APS SENSE  | O   |       | APS Sense Output for APS Control Circuit |
| 28  | APS        |     |       | Adaptive Power Supply                    |
| 29  | APS        |     |       | Adaptive Power Supply                    |
| 30  | 3.3V       |     |       | Power                                    |
| 31  | 3.3V       |     |       | Power                                    |
| 32  | 5.0V       |     |       | Power                                    |
| 33  | GND        |     |       | Electrical Ground                        |
| 34  | GND        |     |       | Electrical Ground                        |
| 35  | GND        |     |       | Electrical Ground                        |
| 36  | GND        |     |       | Electrical Ground                        |
| 37  | GND        |     |       | Electrical Ground                        |
| 38  | RESERVED   |     |       | RESERVED                                 |
| 39  | RESERVED   |     |       | RESERVED                                 |
| 40  | GND        |     |       | Electrical Ground                        |
| 41  | RX LANE 0+ |     |       | Module XAUI Output Lane 0+               |
| 42  | RX LANE 0- |     |       | Module XAUI Output Lane 0-               |
| 43  | GND        |     |       | Electrical Ground                        |
| 44  | RX LANE 1+ |     |       | Module XAUI Output Lane 1+               |
| 45  | RX LANE 1- |     |       | Module XAUI Output Lane 1-               |
| 46  | GND        |     |       | Electrical Ground                        |
| 47  | RX LANE 2+ |     |       | Module XAUI Output Lane 2+               |
| 48  | RX LANE 2- |     |       | Module XAUI Output Lane 2-               |
| 49  | GND        |     |       | Electrical Ground                        |
| 50  | RX LANE 3+ |     |       | Module XAUI Output Lane 2+               |
| 51  | RX LANE 3- |     |       | Module XAUI Output Lane 2-               |
| 52  | GND        |     |       | Electrical Ground                        |
| 53  | GND        |     |       | Electrical Ground                        |
| 54  | GND        |     |       | Electrical Ground                        |
| 55  | RX LANE 0+ |     |       | Module XAUI Output Lane 0+               |
| 56  | RX LANE 0- |     |       | Module XAUI Output Lane 0-               |
| 57  | GND        |     |       | Electrical Ground                        |
| 58  | TX LANE 1+ |     |       | Module XAUI Output Lane 1+               |
| 59  | TX LANE 1- |     |       | Module XAUI Output Lane 1-               |
| 60  | GND        |     |       | Electrical Ground                        |
| 61  | TX LANE 2+ |     |       | Module XAUI Output Lane 2+               |
| 62  | TX LANE 2- |     |       | Module XAUI Output Lane 2-               |

| Pin | Name       | Dir | Logic | Function                   |
|-----|------------|-----|-------|----------------------------|
| 63  | GND        |     |       | Electrical Ground          |
| 64  | TX LANE 3+ |     |       | Module XAUI Output Lane 2+ |
| 65  | TX LANE 3- |     |       | Module XAUI Output Lane 2- |
| 66  | GND        |     |       | Electrical Ground          |
| 67  | RESERVED   |     |       | RESERVED                   |
| 68  | RESERVED   |     |       | RESERVED                   |
| 69  | GND        |     |       | Electrical Ground          |
| 70  | GND        |     |       | Electrical Ground          |

**8. Block Diagram of Adapter Power Supply Circuit**

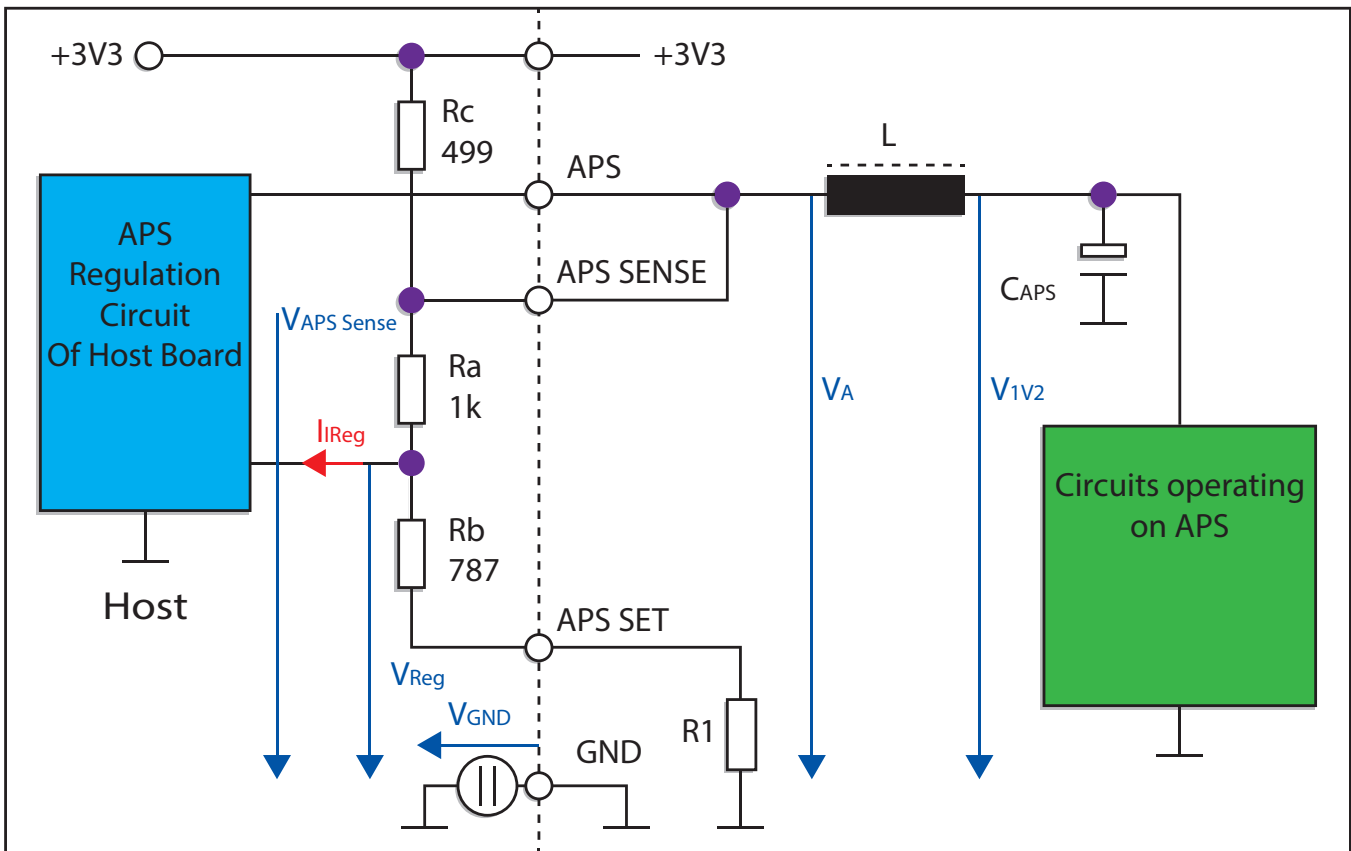



## 9. Package Dimensions

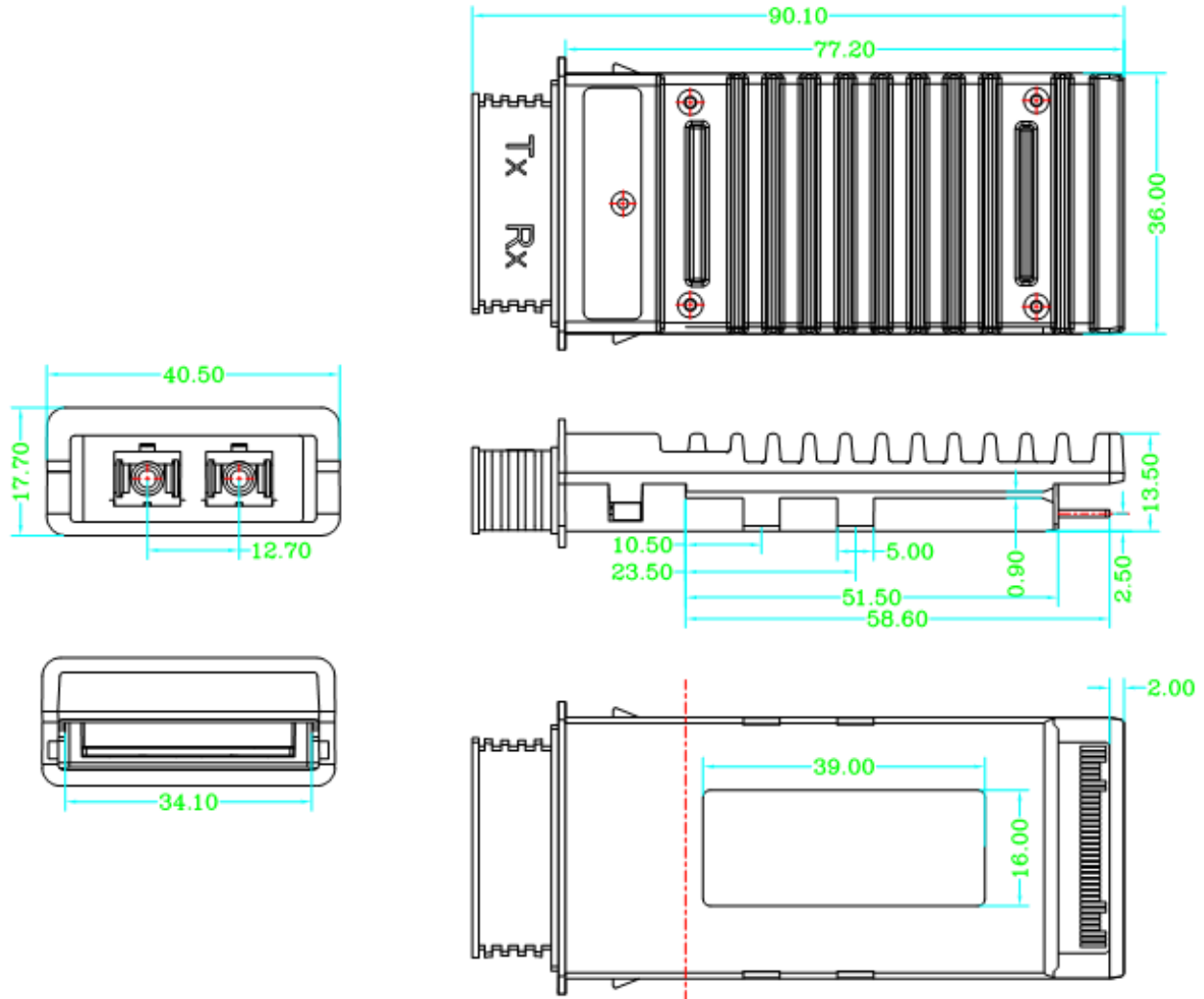

## 10. Contact Information

Approved Networks is a leading supplier of Network Transceivers and Connectivity products to Channel Partners, Resellers, and OEMs. With more than 9 years of direct industry experience, our products are resident in the most demanding and mission critical functional networks Worldwide. We serve as a Master Distributor to the largest CMs in the world and deploy the most rigorous testing and firmware management programs to bring the highest level of functional product to the market at a cost that makes sense.

Corporate Offices: **Approved Networks, Inc.**

Tel: 800.590.9535

Web: <http://www.approvednetworks.com>