

430-4593-A
40GBASE, QSFP+, SR4 Transceiver

Features

- Support up to 40Gb/s bit rates
- Hot-pluggable QSFP+ footprint, Built-in digital diagnostic
- Maximum link length of 100m OM3 MMF and 150m OM4 MMF
- 850VCSEL laser and PIN photodiode
- QSFP+ MSA package with MPO connector
- +3.3V power supply
- Power dissipation < 1.5W
- Temperature range 0~70°C
- RoHS Compliant



Applications

- 40GBASE-SR4
- 40G-IB-QDR
- Parallel optical links

1. Description

Approved Networks QSFP+ SR4 transceivers include a 1 x 4 850nm VCSEL array and 1 x 4 PIN array comply with QSFP+ Multi-Source Agreement (MSA) SFF-8436, and can support applications on 100m OM3 MMF and 150m OM4 MMF. Digital diagnostics functions are available via 2-wire serial interface, which is compliant with QSFP+ MSA.

2. Absolute Maximum Ratings

These values represent the damage threshold of the module. Stress in excess of any of the individual absolute maximum ratings can cause immediate catastrophic damage to the module even if all other parameters are within recommended Operating conditions.

Parameter	Symbol	Min.	Max.	Unit	Notes
Storage Temperature	Ts	-40	85	°C	-
Operating Case Temperature	Top	0	70	°C	-
Power supply Voltage	Vcc	0	3.6	V	-
Relative Humidity	RH	0	85	%	-
Maximum Optical Input Power	Pin	3.4		dBm	-

3. Recommended Operating Conditions

Parameter	Symbol	Min.	Typ.	Max.	Unit
Operating Case Temperature	TC	0		+70	°C
Power Supply Voltage	Vcc	3.14	3.3	3.47	V
Power Supply Current	ICC			430	mA
Power Dissipation	PD			1.5	W
Data Rate per Lane	DR		10.3125		Gbps
Link Distance on OM3 MMF				100	m
Link Distance on OM4 MMF				150	m

4. Transmitter Specification (Electrical)

Parameter	Symbol	Min.	Typ.	Max.	Unit
Differential Data Input Voltage Swing	Vin, p-p	500		1600	mV
Input Differential Impedance	Rin		100		Ω
Input High Voltage (ResetL - LPMode)	VIH	+2.0		VCC	V
Input LOW Voltage (ResetL - LPMode)	VIL	0		+0.8	V
Output High Voltage (IntL)	VOH	VCC-0.5		VCC	V
Output LOW Voltage (IntL)	VOL	0		+0.4	V

4. Transmitter Specification (Optical)

Parameter	Symbol	Min.	Typ.	Max.	Unit	Condition
Data Rate, each lane			10.3125	11.2		Gbps
Center wavelength	λ_C	840	850	860	nm	
RMS spectral width	$\Delta\lambda$			0.65	nm	10.3125Gps, PRBS2^31-1, NRZ
Extinction Ratio ER 3 5 dB						
Average launch power	PO,AVG	-7.6		2.4	dBm	
Optical Modulation						
Amplitude (OMA)	PO,OMA	-5.6		3.0	dBm	
Difference in launch power between any two lanes (OMA)				4	dB	
Peak power	PO,PEAK			4	dBm	
Launch power in OMA minus TDP		-6.5			dBm	
Transmitter and Dispersion penalty (TDP)	TDP			3.5	dB	
Extinction Ratio	ER	3			dB	
Optical return loss tolerance				12	dB	
Average launch power of OFF transmitter	POFF			-30	dBm	
Encircled Flux		>86% at 19um <30% at 4.5um				

5. Receiver Specification (Optical)

Parameter	Symbol	Min.	Typ.	Max.	Unit	Condition
Average receiver power	Pin, AVG	-9.5		2.4	dBm	
Receiver reflectance				-12	dBm	
Receiver power (OMA)	Pin, OMA			3	dBm	
Stressed receiver sensitivity (OMA)				-5.4	dBm	
Peak power	PO, PEAK			4	dBm	
LOS Assert	LOS	-30			dBm	
LOS De-assert	LOSD			-22	dBm	
LOS Hysteresis	LOSH	0.5			dBm	

6. Receiver Specification (Electrical)

Parameter	Symbol	Min.	Typ.	Max.	Unit	Condition
Differential Data Output Voltage Swing	Vout, p-p	200	800	mV		
Output Differential Impedance	Rout		100		Ω	

7. Pin Definition

The QSFP+ modules are hot-pluggable. Hot pluggable refers to plugging in or unplugging a module while the host board is powered. The QSFP+ hot connector is a 0.8mm pitch 38 position right angle improved connector specified by SFF-8436, or stacked connector with equivalent electrical performance. Host PCB contact assignment is shown in Figure 1 and contact definitions are given in the table below.

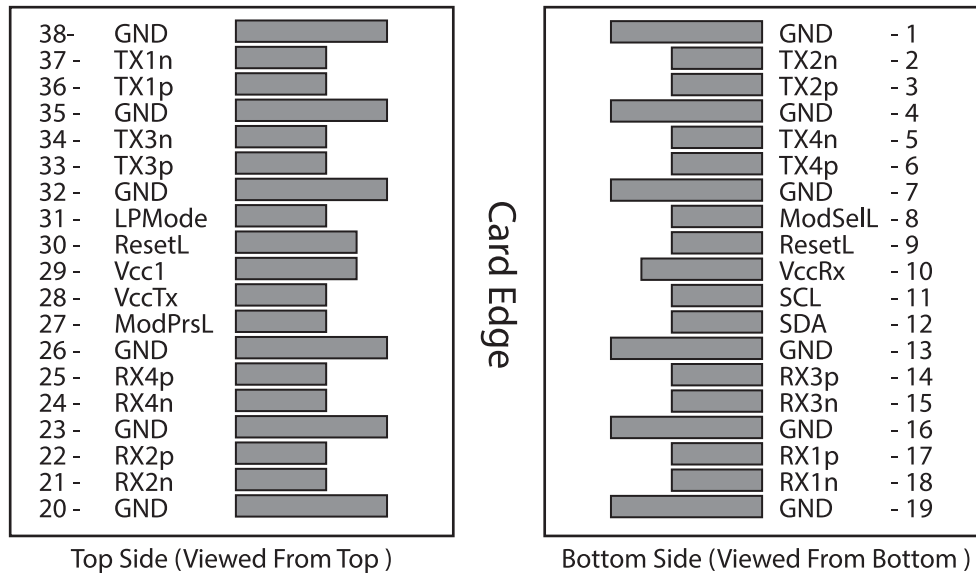

Top Side (Viewed From Top)

Bottom Side (Viewed From Bottom)

Figure 1. Interface to Host PCB

Pin	Logic	Symbol	Name/Description
1		GND	Module Ground
2	CML-I	Tx2n	CH2 Transmitter Inverted Data Input
3	CML-I	Tx2p	CH2 Transmitter Non-inverted Data Input
4		GND	Module Ground
5	CML-I	Tx4n	CH4 Transmitter Inverted Data Input
6	CML-I	Tx4p	CH4 Transmitter Non-inverted Data Input
7		GND	Module Ground
8	LVTTL-I	ModSelL	Module Select
9	LVTTL-I	ResetL	Module Reset
10		VccRX	+3.3V Power Supply Receiver
11	LVC MOS-I/O	SCL	2-wire serial interface clock

Pin	Logic	Symbol	Name/Description
12	LVC MOS-I/O	SDA	2-wire serial interface data
13		GND	Module Ground
14	CML-O	Rx3p	CH3 Receiver Non-inverted Data Input
15	CML-O	Rx3n	CH3 Receiver Inverted Data Input
16		GND	Module Ground
17	CML-O	Rx1p	CH1 Receiver Non-inverted Data Input
18	CML-O	Rx1n	CH1 Receiver Inverted Data Input
19		GND	Module Ground
20		GND	Module Ground
21	CML-O	Rx2n	CH2 Receiver Inverted Data Input
22	CML-O	Rx2p	CH2 Receiver Non-inverted Data Input
23		GND	Module Ground
24	CML-O	Rx4n	CH4 Receiver Inverted Data Input
25	CML-O	Rx4p	CH4 Receiver Non-inverted Data Input
26		GND	Module Ground
27	LVTTL-O	ModPrsL	Module Present
28	LVTTL-O	IntL	Interrupt
29		VccTX	+3.3V Power Supply Transmitter
30		Vcc1	+3.3V Power Supply
31	LVTTL-I	LPMODE	Low Power Mode
32		GND	Module Ground
33	CML-I	Tx3p	CH3 Transmitter Non-inverted Data Input
34	CML-I	Tx3n	CH3 Transmitter Inverted Data Input
35		GND	Module Ground
36	CML-I	Tx1p	CH1 Transmitter Non-inverted Data Input
37	CML-I	Tx1n	CH1 Transmitter Inverted Data Input
38		GND	Module Ground

Notes:

1. Module circuit ground is isolated from module chassis ground within the module
2. Open collector, should be pulled up with 4.7K-10K ohms on the host board to a voltage between 3.15V and 3.6V.

8. 2-wire Management Interface

The transceivers provide management two-wire interface and the management memory map is specified by SFF-8436.

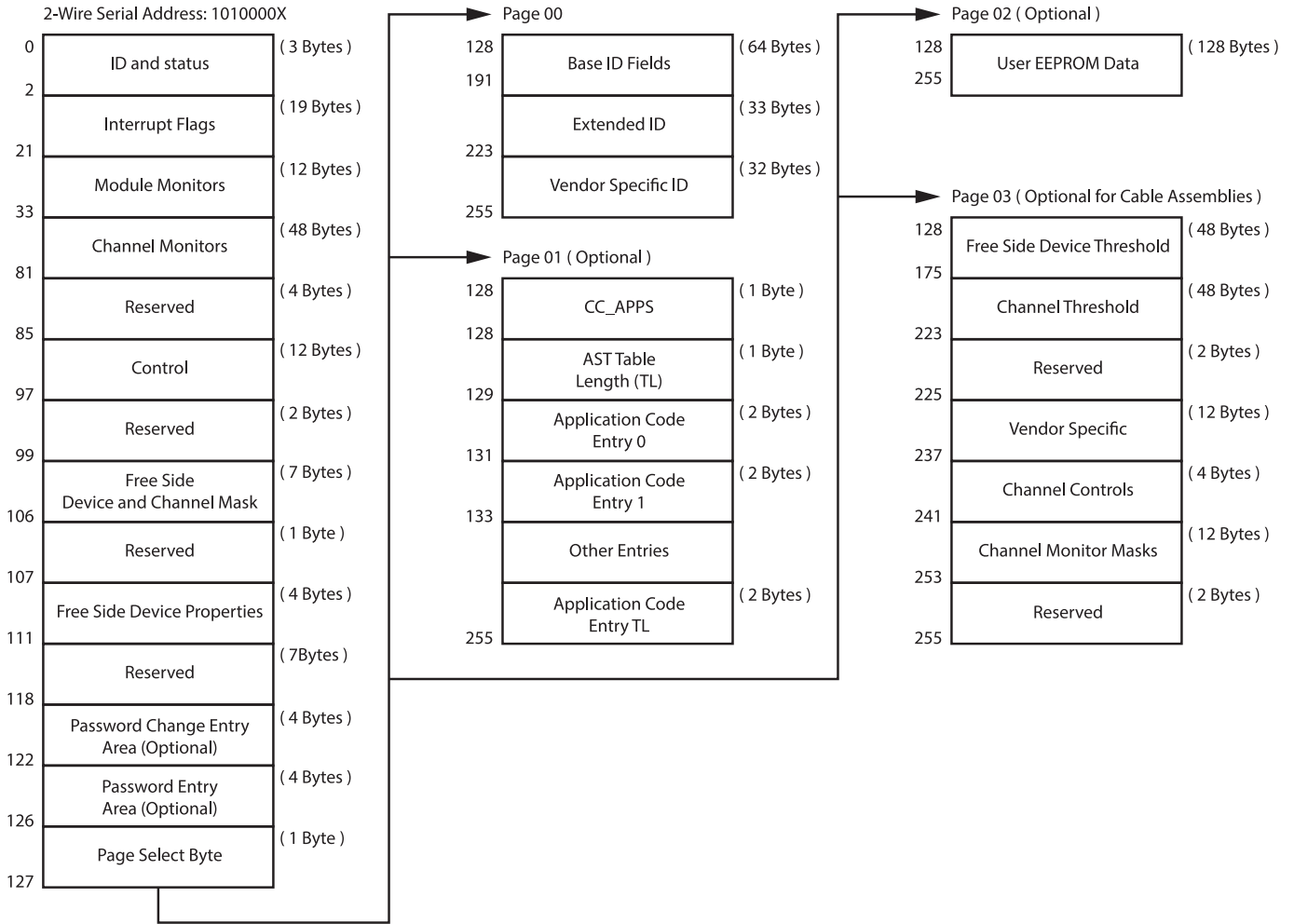

9. ESD

This module high speed pins withstand 1KV electrostatic discharge on Human Body Model per JESD22-A114. The exception of high speed pins withstand 2KV electrostatic discharge based on Human Body Model per JESD 22-A114. The QSFP+ module meet ESD requirement in EN61000-4-2, criterion B test specification. The transceiver is shipped in ESD protective packaging. It should be removed from the packaging and handled only in an ESD protected environment.

10. Package Dimentions (Unit: MM)

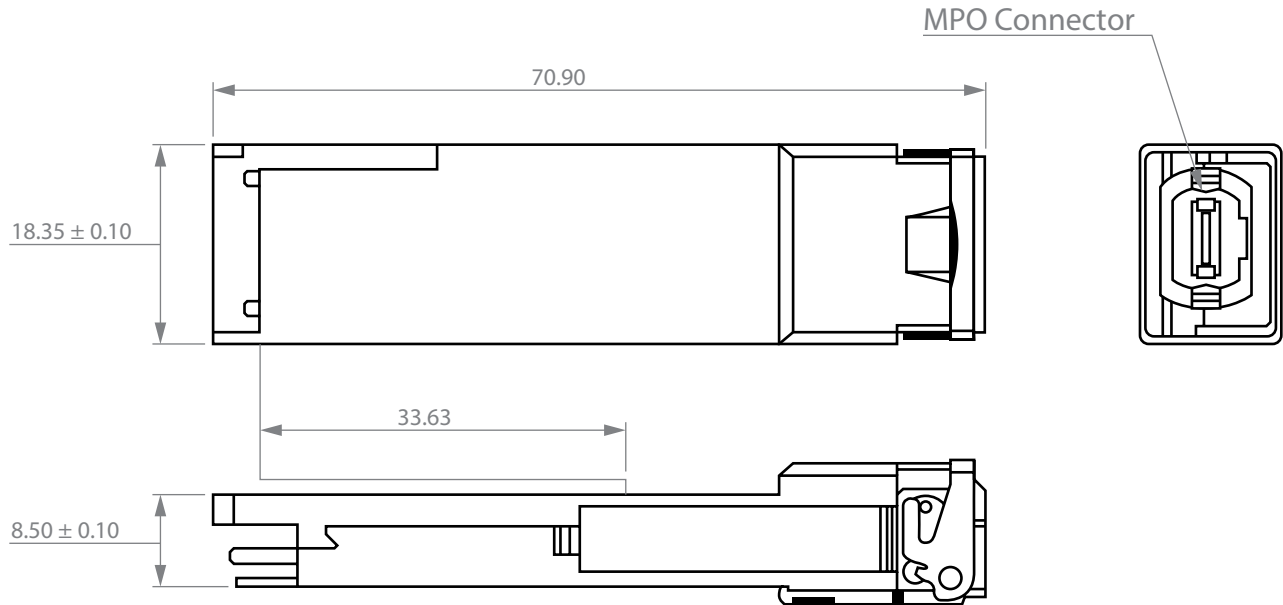

11. Contact Information

Approved Networks is a leading supplier of Network Transceivers and Connectivity products to Channel Partners, Resellers, and OEMs. With more than 9 years of direct industry experience, our products are resident in the most demanding and mission critical functional networks Worldwide. We serve as a Master Distributor to the largest CMs in the world and deploy the most rigorous testing and firmware management programs to bring the highest level of functional product to the market at a cost that makes sense.

Corporate Offices: **Approved Networks, Inc.**

Tel: 800.590.9535

Web: <http://www.approvednetworks.com>