

10G-SFPP-BXU-80-A
10GBASE, SFP+, ZR, BIDI Transceiver

Features

- Supports 9.95 to 11.3Gb/s bit rates
- Hot-Pluggable
- Single LC for Bi-directional Transmission
- cooled EML transmitter, APD photo-detector
- SMF links up to 80km
- 2-wire interface for management specifications compliant with SFF 8472 digital diagnostic monitoring interface
- Power Supply :+3.3V
- Power consumption<3W
- Temperature Range: 0~ 70°C
- RoHS compliant



Applications

- 10GBASE-ZR/ZW Ethernet
- SONET OC-192 / SDH
- 10G Fibre channel

1. Description

Approved Networks' SFP+ ZR BIDI is a very compact 10Gb/s optical transceiver module for serial optical communication applications at 10Gb/s. The transceiver converts a 10Gb/s serial electrical data stream to 10Gb/s optical output signal and a 10Gb/s optical input signal to 10Gb/s serial electrical data streams. The high speed 10Gb/s electrical interface is fully compliant with SFI specification.

The high performance 1490/1570nm cooled EML transmitter and high sensitivity APD receiver provide superior performance for Ethernet applications at up to 80km links.

The SFP+ Module compliants with SFF-8431, SFF-8432 and IEEE 802.3ae 10GBASE-ZR. Digital diagnostics functions are available via a 2-wire serial interface, as specified in SFF-8472.

The fully SFP compliant form factor provides hot plug-ability, easy optical port upgrades and low EMI emission.

2. Absolute Maximum Ratings

Parameter	Symbol	Min.	Typical	Max.	Unit
Storage Temperature	TS	-40		+85	°C
Case Operating Temperature	TA	0		70	°C
Maximum Supply Voltage	Vcc	-0.5		4	V
Relative Humidity	RH	0		85	%

3. Electrical Characteristics (TOP = 0 to 70 °C, VCC = 3.135 to 3.465 Volts)

Parameter	Symbol	Min.	Typical	Max.	Unit	Note
Supply Voltage	Vcc	3.135		3.465	V	
Supply Current	Icc			500	mA	
Power Consumption	P			1.8	W	
Transmitter						
Parameter	Symbol	Min.	Typical	Max.	Unit	Note
Input differential impedance	Rin		100		Ω	1
Tx Input Single Ended DC Voltage Tolerance (Ref VeeT)	V	-0.3		4	V	
Differential input voltage swing	Vin,pp	180		700	mV	2
Transmit Disable Voltage	VD	2		Vcc	V	3
Transmit Enable Voltage	VEN	Vee		Vee+0.8	V	
Receiver						
Parameter	Symbol	Min.	Typical	Max.	Unit	Note
Single Ended Output Voltage Tolerance	V	-0.3		4	V	
Rx Output Diff Voltage	Vo	300		850	mV	
Rx Output Rise and Fall Time	Tr/Tf	30			ps	4
LOS Fault	VLOS fault	2		Vcc HOST	V	5
LOS Normal	VLOS norm	Vee		Vee+0.8	V	5

Notes:

1. Connected directly to TX data input pins. AC coupling from pins into laser driver IC.
2. Per SFF-8431 Rev 3.0
3. Into 100 ohms differential termination.
4. 20%~80%

- LOS is an open collector output. Should be pulled up with 4.7k – 10kΩ on the host board. Normal operation is logic 0; loss of signal is logic 1. Maximum pull-up voltage is 5.5V.

4. Optical Parameters (TOP = 0 to 70°C, VCC = 3.135 to 3.465 Volts)

Transmitter						
Parameter	Symbol	Min.	Typical	Max.	Unit	Note
Center Wavelength	λ_t		1490		nm	
Spectral Width	λ			0.3	nm	
Average Optical Power	Pavg	0		+5	dBm	1
Optical Power OMA	Poma	-2.1			dBm	
Laser Off Power	Poff			-30	dBm	
Extinction Ratio	ER	8.2			dB	
Transmitter Dispersion Penalty	TDP			3.0	dB	2
Relative Intensity Noise	Rin			-128	dB/Hz	3
Optical Return Loss Tolerance		21			dB	
Receiver						
Parameter	Symbol	Min.	Typical	Max.	Unit	Note
Center Wavelength	λ_r		1570		nm	
Receiver Sensitivity	Sen			-23	dBm	4
Los Assert	LOSA	-34		-	dBm	
Los Deassert	LOSD			-24	dBm	
Los Hysteresis	LOSH	0.5			dB	
Overload	Sat	-7			dBm	5
Receiver Reflectance	Rrx			-26	dB	

Notes:

- Average power figures are informative only, per IEEE802.3ae.
- TWDP figure requires the host board to be SFF-8431 compliant. TWDP is calculated using the Matlab code provided in clause 68.6.6.2 of IEEE802.3ae.
- 12dB reflection.
- Conditions of stressed receiver tests per IEEE802.3ae. CSRS testing requires the host board to be SFF-8431 compliant.

5. Timing Characteristics

Parameter	Symbol	Min.	Typ	Max.	Unit
TX_Disable Assert Time	t_off			10	us
TX_Disable Negate Time	t_on			1	ms
Time to Initialize Include Reset of TX_FAULT	t_int			300	ms
TX_FAULT from Fault to Assertion	t_fault			100	us
TX_Disable Time to Start Reset	t_reset	10			us
Receiver Loss of Signal Assert Time	TA,RX_LOS			100	us
Receiver Loss of Signal Deassert Time	Td,RX_LOS			100	us
Rate-Select Chage Time	t_ratesel			10	us
Serial ID Clock Time	t_serial-clock			100	kHz

6. Pin Assignment

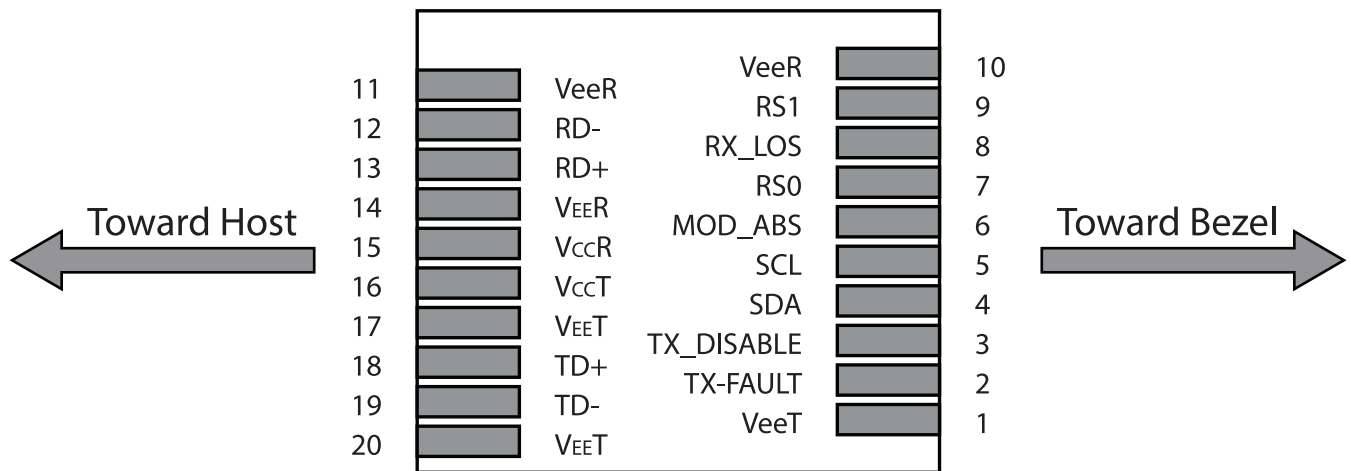

Figure 1: Module Interface to Host

7. Pin Function Definitions

PIN #	Name	Function	Notes
1	VeeT	Module transmitter ground	1
2	Tx Fault	Module transmitter fault	2
3	Tx Disable	Transmitter Disable; Turns off transmitter laser output	3
4	SDL	2 wire serial interface data input/output (SDA)	
5	SCL	2 wire serial interface clock input (SCL)	
6	MOD-ABS	Module Absent, connect to VeeR or VeeT in the module	2
7	RS0	Rate select0, optionally control SFP+ receiver. When high, input data rate >4.5Gb/ s; when low, input data rate <=4.5Gb/s	
8	LOS	Receiver Loss of Signal Indication	4

PIN #	Name	Function	Notes
9	RS1	Rate select0, optionally control SFP+ transmitter. When high, input data rate >4.5Gb/s; when low, input data rate <=4.5Gb/s	
10	VeeR	Module receiver ground	1
11	VeeR	Module receiver ground	1
12	RD-	Receiver inverted data out put	
13	RD+	Receiver non-inverted data out put	
14	VeeR	Module receiver ground	1
15	VccR	Module receiver 3.3V supply	
16	VccT	Module transmitter 3.3V supply	
17	VeeT	Module transmitter ground	1
18	TD+	Transmitter inverted data out put	
19	TD-	Transmitter non-inverted data out put	
20	VeeT	Module transmitter ground	

Notes:

1. The module ground pins shall be isolated from the module case.
2. This pin is an open collector/drain output pin and shall be pulled up with 4.7K-10Kohms to Host_Vcc on the host board.
3. This pin shall be pulled up with 4.7K-10Kohms to VccT in the module.
4. This pin is an open collector/drain output pin and shall be pulled up with 4.7K-10Kohms to Host_Vcc on the host board.

8. FP Module EEPROM Information and Management

The SFP modules implement the 2-wire serial communication protocol as defined in the SFP -8472. The serial ID information of the SFP modules and Digital Diagnostic Monitor parameters can be accessed through the I2C interface at address A0h and A2h. The memory is mapped in Table 1. Detailed ID information (A0h) is listed in Table 2. And the DDM specification at address A2h. For more details of the memory map and byte definitions, please refer to the SFF-8472, "Digital Diagnostic Monitoring Interface for Optical Transceivers". The DDM parameters have been internally calibrated.

10G-SFPP-BXU-80-A

10GBASE, SFP+, ZR, BIDI, (SM)

TX 1490 NM / RX 1570 NM , 80 KM REACH, LC

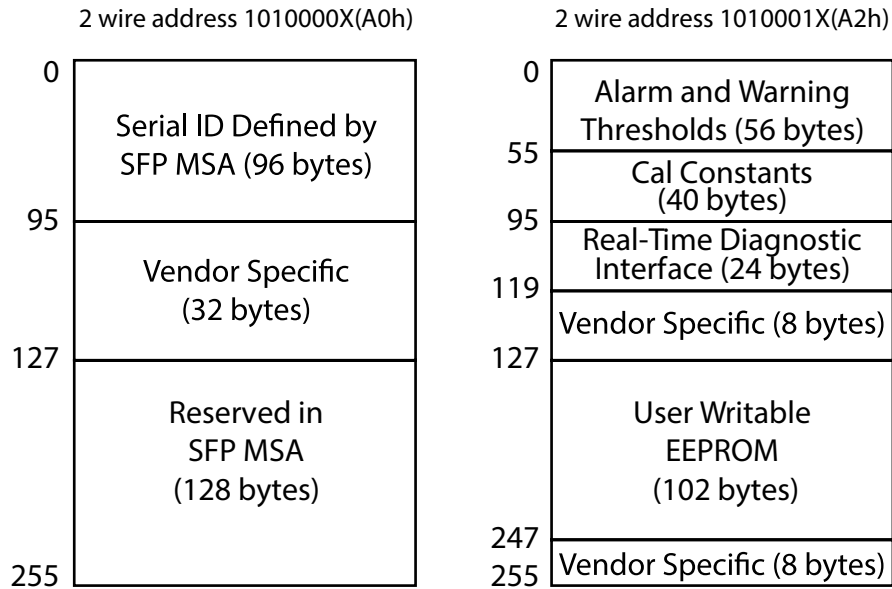

Figure 2: Digital Diagnostic Memory Map (Specific Data Field Descriptions)

9. EEPROM Serial ID Memory Contents (A0h)

Base ID Fields			
Data Address	Length (Byte)	Name of Length	Description and Contents
0	1	Identifier	Type of Serial transceiver (03h=SFP)
1	1	Reserved	Extended identifier of type serial transceiver (04h)
2	1	Connector	Code of optical connector type (07=LC)
3-10	8	Transceiver	10G Base-ZR
11	1	Encoding	64B/66B
12	1	BR, Nominal	Nominal baud rate, unit of 100Mbps
13-14	2	Reserved	(0000h)
15	1	Length(9um)	Link length supported for 9/125um fiber, units of 100m
16	1	Length(50um)	Link length supported for 50/125um fiber, units of 10m
17	1	Length(62.5um)	Link length supported for 62.5/125um fiber, units of 10m
18	1	Length(Copper)	Link length supported for copper, units of meters
19	1	Reserved	
20-35	16	Vendor Name	SFP vendor name: Approved Networks
36	1	Reserved	
37-39	3	Vendor OUI	SFP transceiver vendor OUI ID

Base ID Fields			
Data Address	Length (Byte)	Name of Length	Description and Contents
40-55	16	Vendor PN	Part Number (ASCII)
56-59	4	Vendor rev	Revision level for part number
60-62	3	Reserved	
63	1	CCID	Least significant byte of sum of data in address 0-62
Extended ID Fields			
Data Address	Length (Byte)	Name of Length	Description and Contents
64-65	2	Option	Indicates which optical SFP signals are implemented (001Ah = LOS, TX_FAULT, TX_DISABLE all supported)
66	1	BR, max	Upper bit rate margin, units of %
67	1	BR, min	Lower bit rate margin, units of %
68-83	16	Vendor SN	Serial number (ASCII)
84-91	8	Date code	Approved Networks Manufacturing date code
92-94	3	Reserved	
95	1	CCEX	Check code for the extended ID Fields (addresses 64 to 94)
Vendor Specific ID Fields			
Data Address	Length (Byte)	Name of Length	Description and Contents
96-127	32	Readable	Approved Networks specific date, read only
128-255	128	Reserved	Reserved for SFF-8079

10. Digital Diagnostic Monitor Characteristics

Data Address	Parameter	Accuracy	Unit
96-97	Transceiver Internal Temperature	±3.0	°C
98-99	VCC3 Internal Supply Voltage	±3.0	%
100-101	Laser Bias Current	±10	%
102-103	Tx Output Power	±3.0	dB
104-105	Rx Input Power	±3.0	dB

11. Regulatory Compliance

This unit complies with international Electromagnetic Compatibility (EMC) and international safety requirements and standards (see details in Table following).

Electrostatic Discharge (ESD) to the Electrical Pins	MIL-STD-883E Method 3015.7	Class 1(>1000 V)
Electrostatic Discharge (ESD) to the Single LC Receptacle	IEC 61000-4-2 GR-1089-CORE	Compatible with standards
Electromagnetic Interference (EMI)	FCC Part 15 Class B EN55022 Class B (CISPR 22B) VCCI Class B	Compatible with standards
Laser Eye Safety	FDA 21CFR 1040.10 and 1040.11 EN60950, EN (IEC) 60825-1,2	Compatible with Class 1 laser product.

12. Recommended Circuit

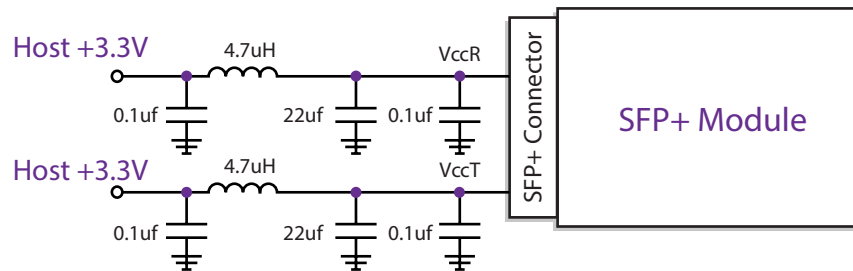

Figure 3: Recommended Host Board Power Supply Circuit

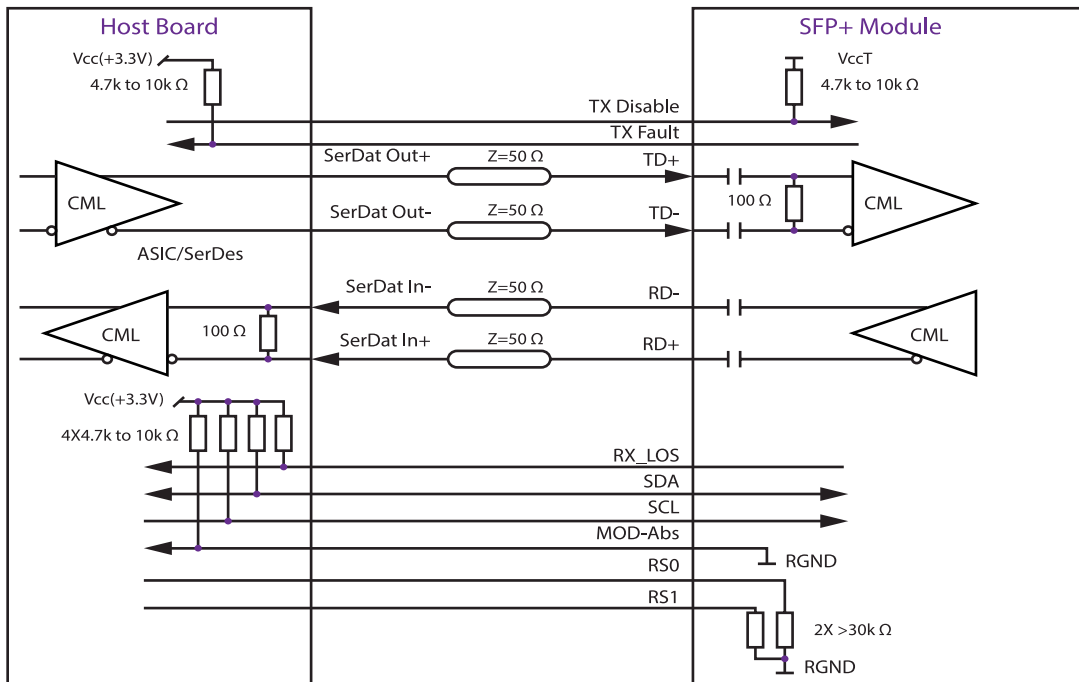
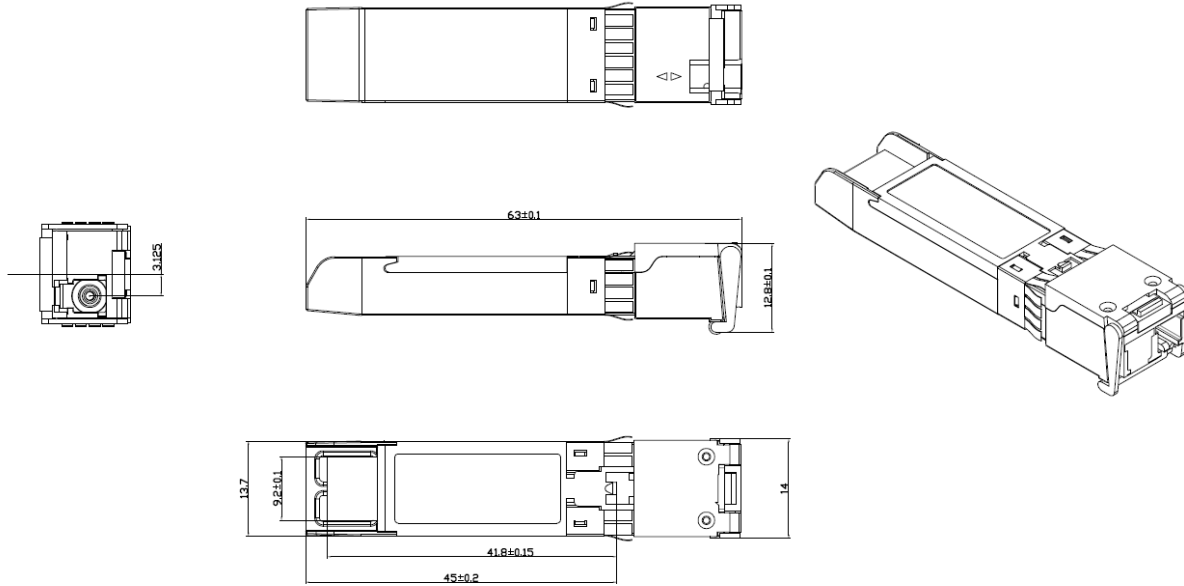

Figure 4: Recommended High-speed Interface Circuit

13. Mechanical Dimensions



14. Contact Information

Approved Networks is a leading supplier of Network Transceivers and Connectivity products to Channel Partners, Resellers, and OEMs. With more than 9 years of direct industry experience, our products are resident in the most demanding and mission critical functional networks Worldwide. We serve as a Master Distributor to the largest CMs in the world and deploy the most rigorous testing and firmware management programs to bring the highest level of functional product to the market at a cost that makes sense.

Corporate Offices: **Approved Networks, Inc.**

Tel: 800.590.9535

Web: <http://www.approvednetworks.com>